

WALL HANGING GUITAR DISPLAY CASE

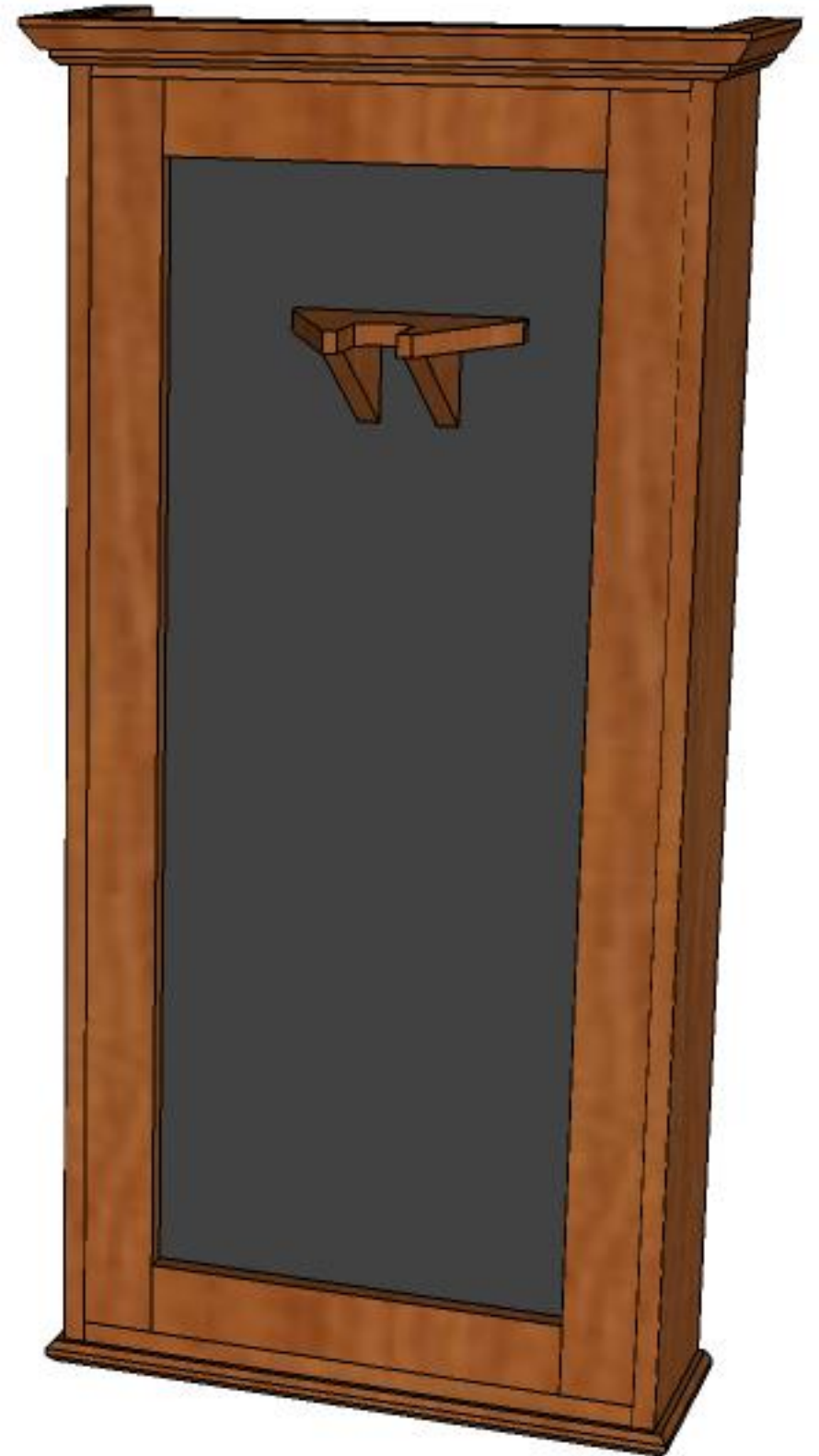

CUTTING DIAGRAM

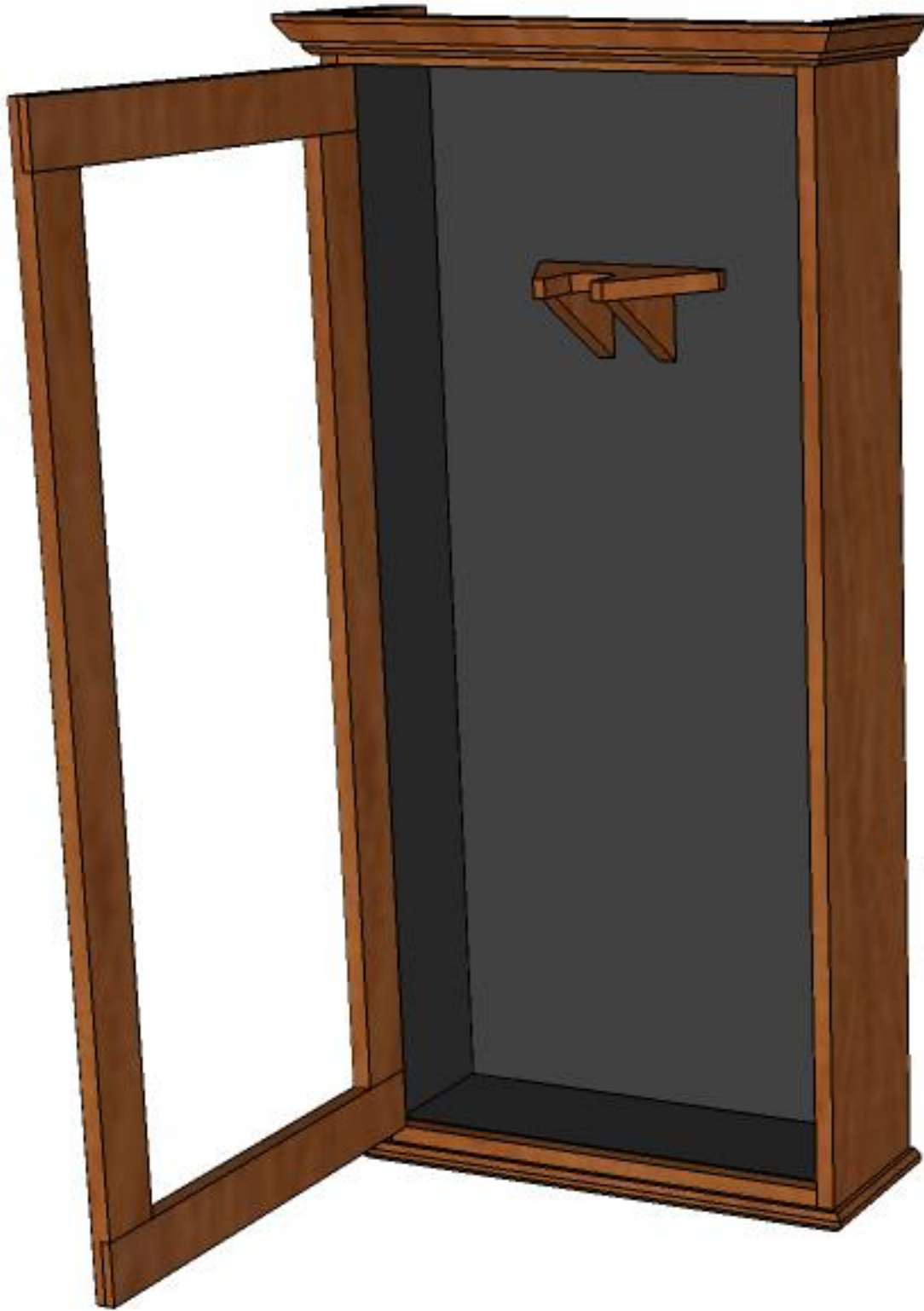
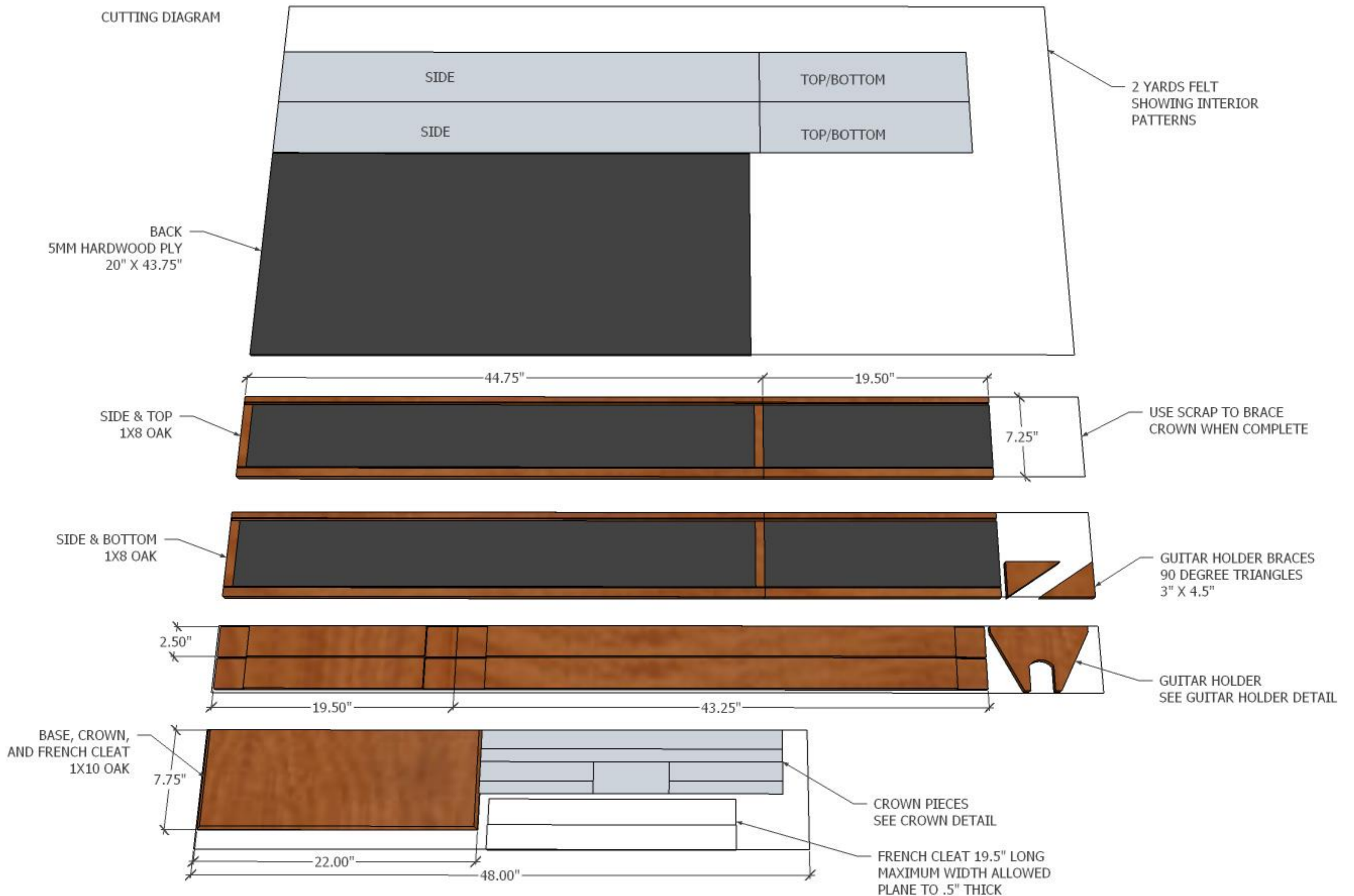

CROWN DETAIL

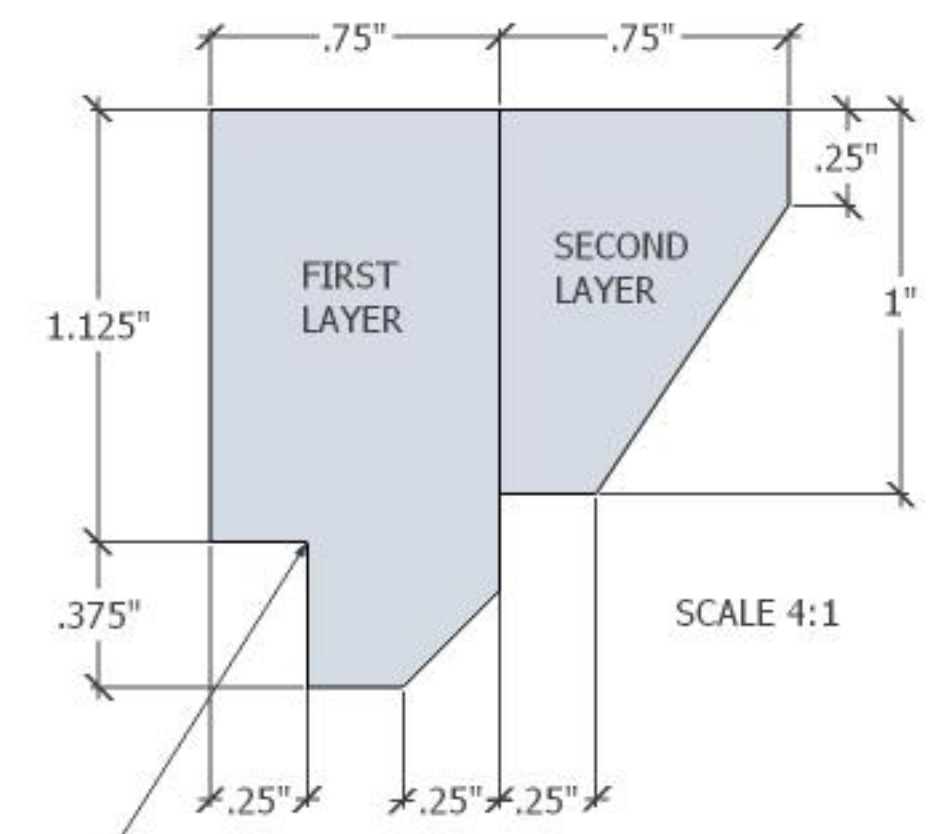
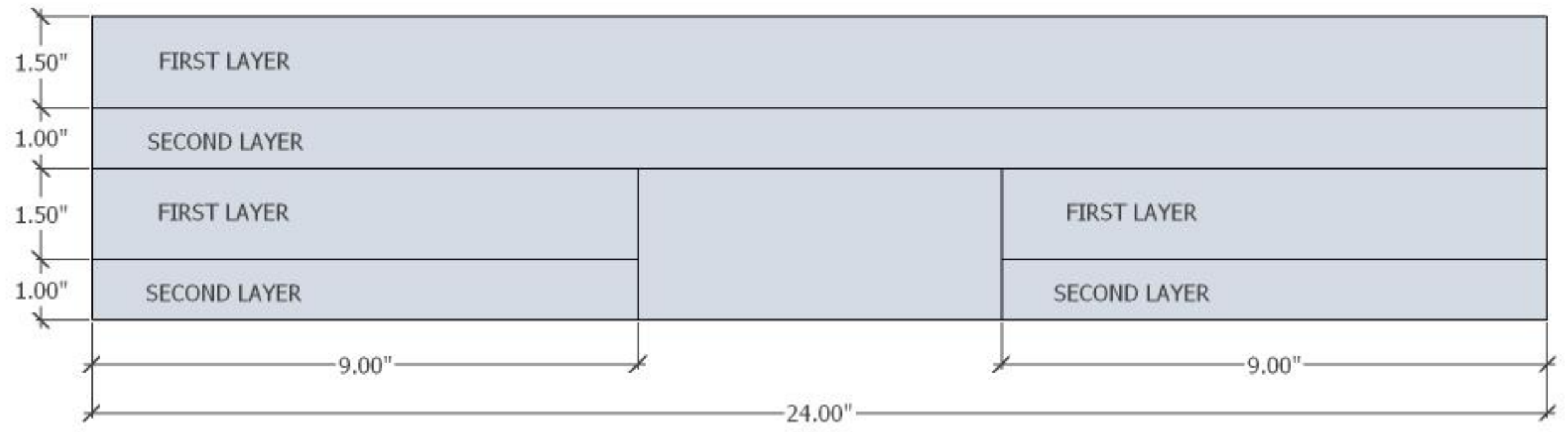
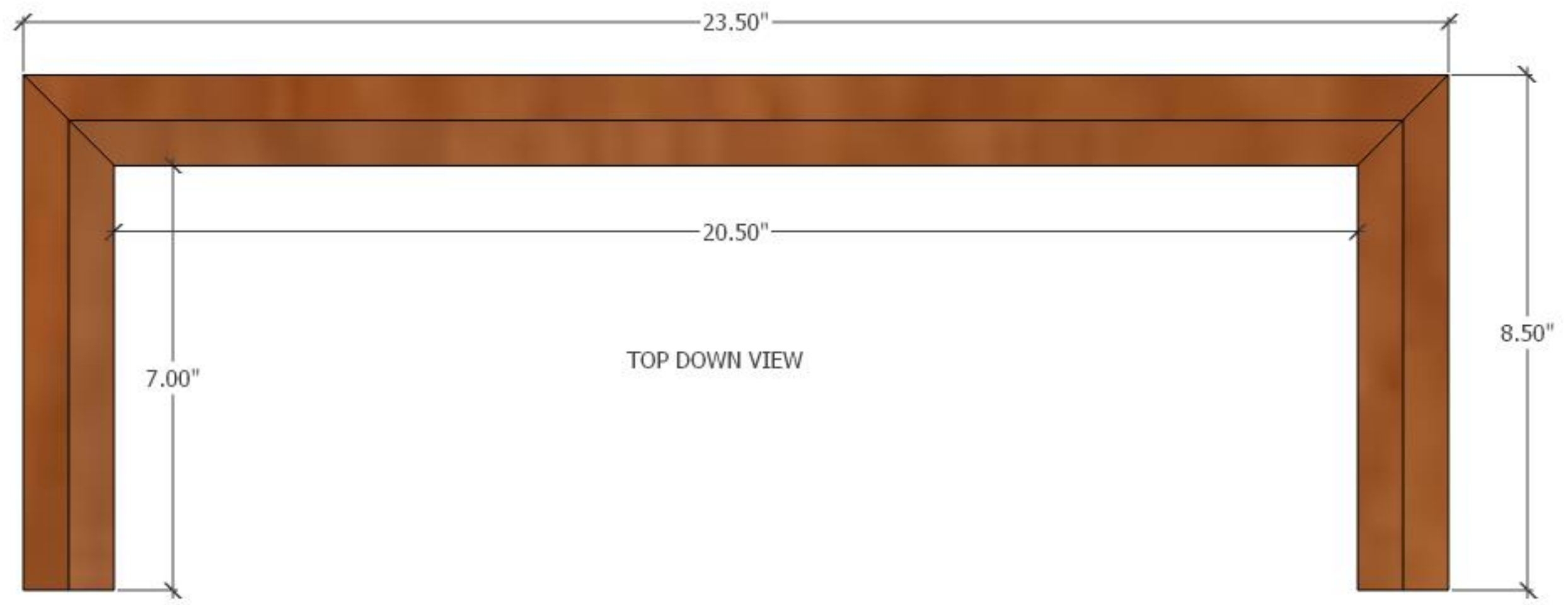

GUITAR HOLDER DETAIL

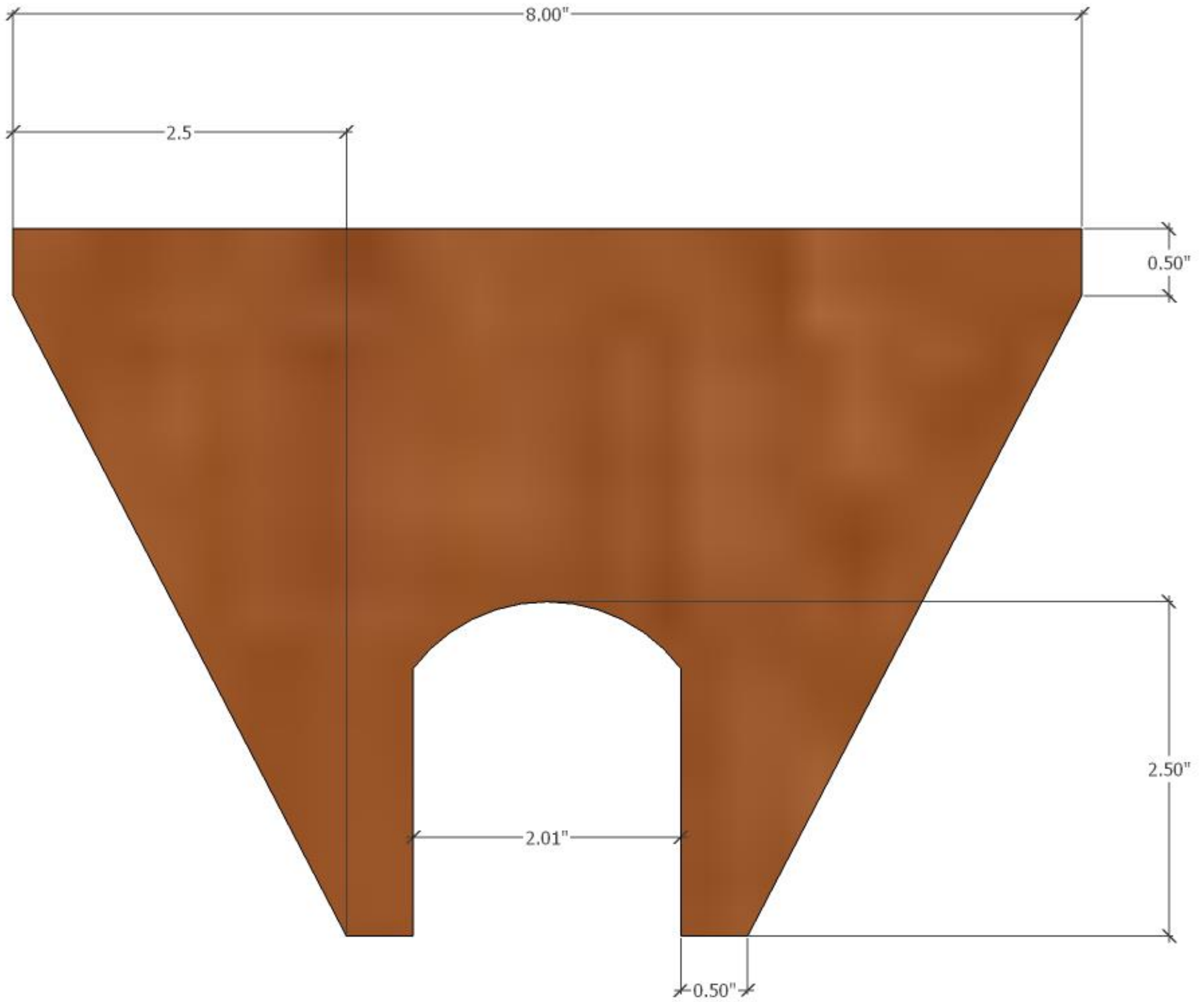

TOP AND BOTTOM DETAIL

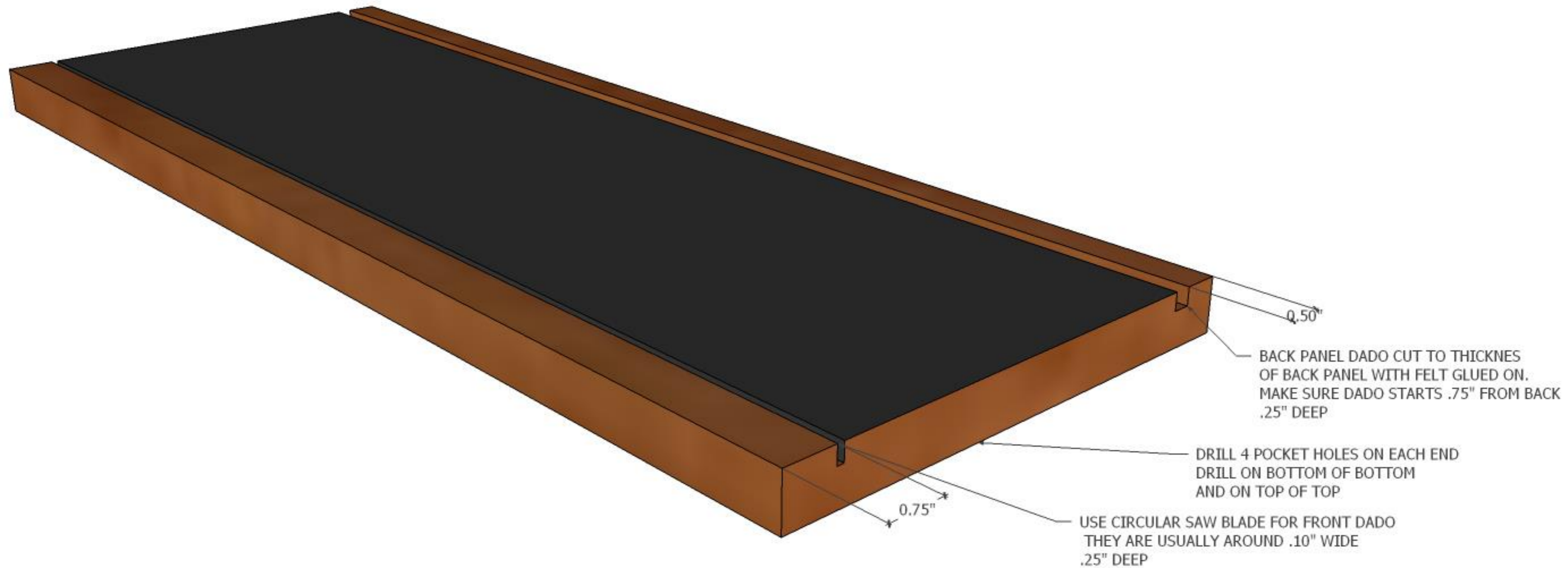

SIDES DETAIL



SAME FELT PLACEMENT EXCEPT
LEAVE TOP AND BOTTOM .75" EMPTY

SAME DADO PLACEMENT AS
TOP AND BOTTOM PIECES

FRAME AND BACK ASSEMBLY

SECURE TOP TO SIDES WITH POCKET HOLE SCREWS

SLIDE BACK IN BEFORE SECURING
LAST FRAME PIECE

SECURE BOTTOM TO SIDES WITH POCKET HOLE SCREWS

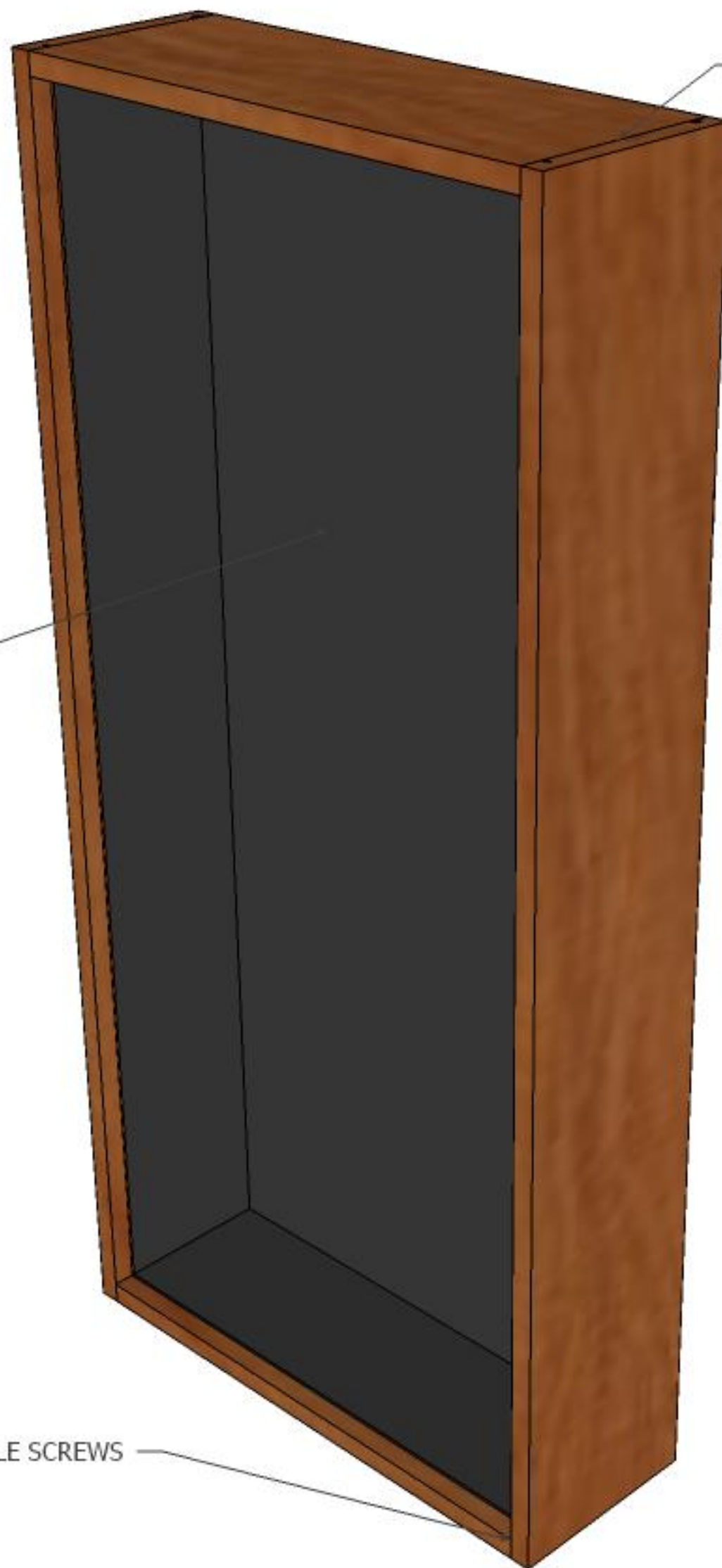

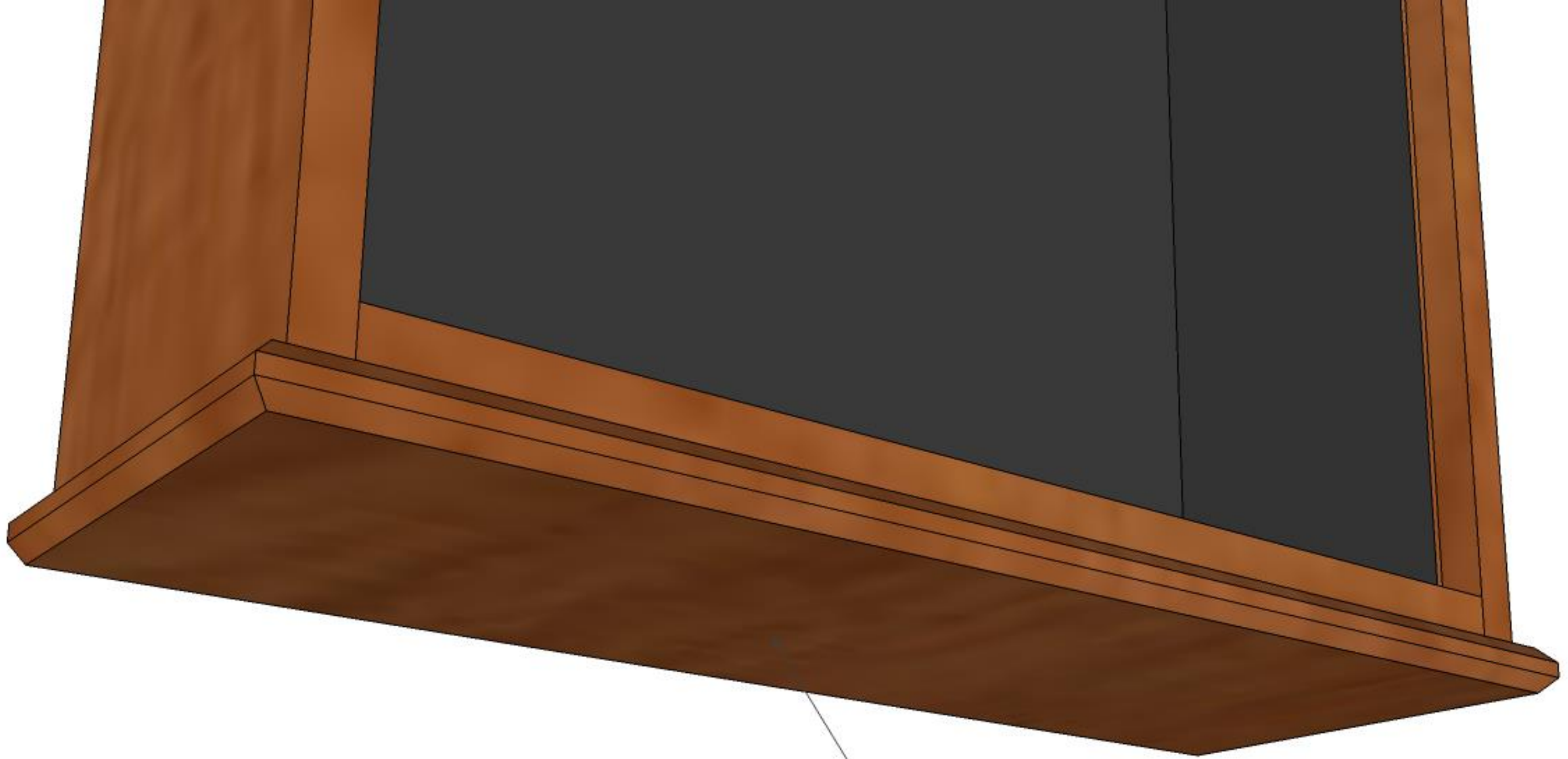

BASE IS CENTERED AND FLUSH IN THE BACK
ATTACH HOWEVER YOU WISH
USE SCREWS, JUST GLUE, BISCUITS, DOWELS OR WHATEVER METHOD YOU PREFER

BASE

BACK DETAIL

ATTACH FRENCH CLEAT WITH TWO POCKET HOLE
SCREWS AT EACH END

MAKE SURE THE CLEAT HAS THE SMALLER
SIDE AGAINST THE BACK PANEL

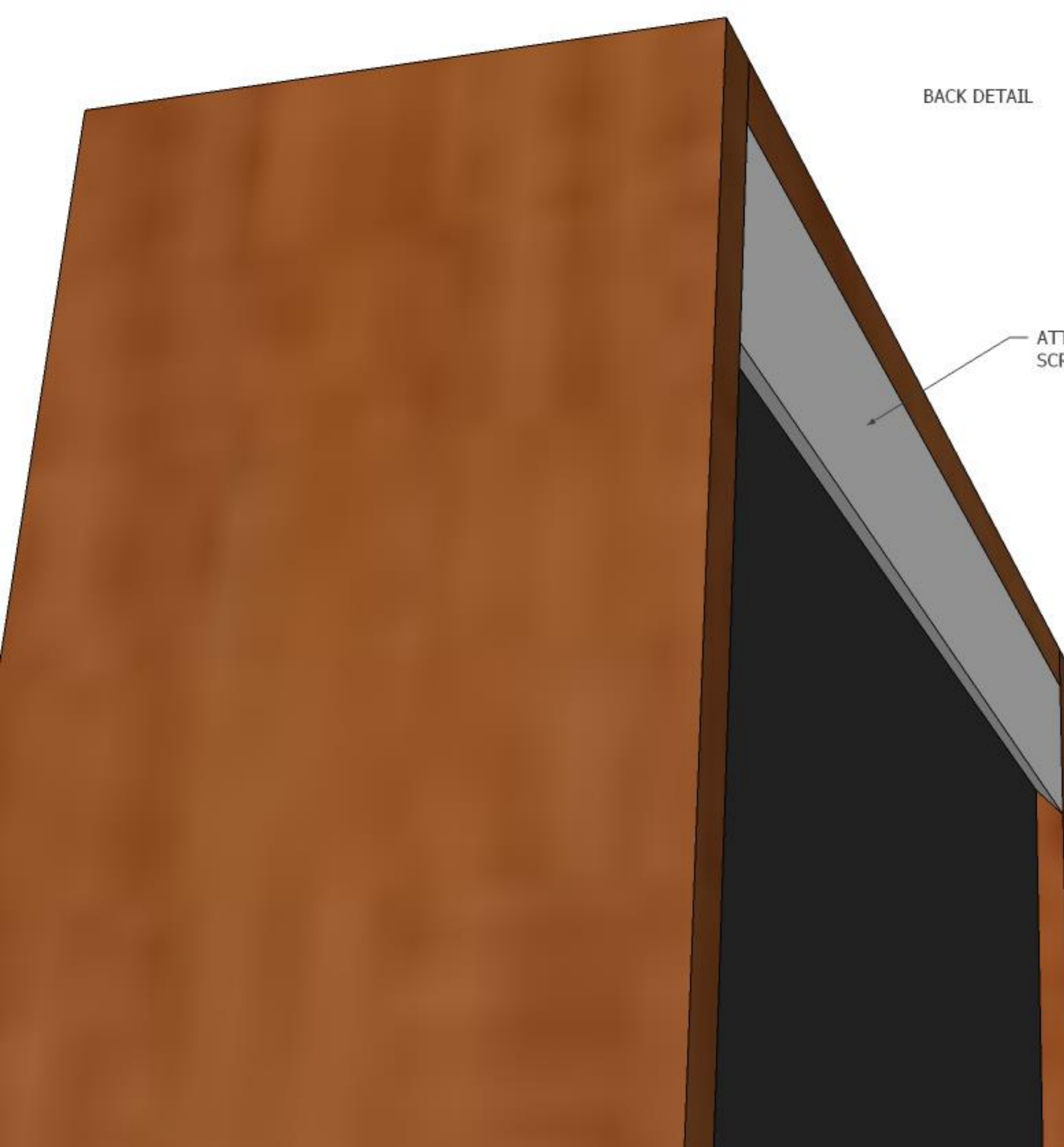

CROWN ASSEMBLY

ADD EXTRA BRACING AS NEEDED WITH SCRAP MATERIALS

CROWN PIECES FIT IN RABBET



DOOR DETAIL

ALL JOINTS ARE HALF LAP JOINTS

AFTER ASSEMBLED
ROUT A .5" WIDE RABBET
ON THE INSIDE TO ACCEPT
GLASS OR ACRYLIC
DEPTH DETERMINED BY
YOUR GLASS OR ACRYLIC
THICKNESS. USE THUMB TACKS
TO SECURE

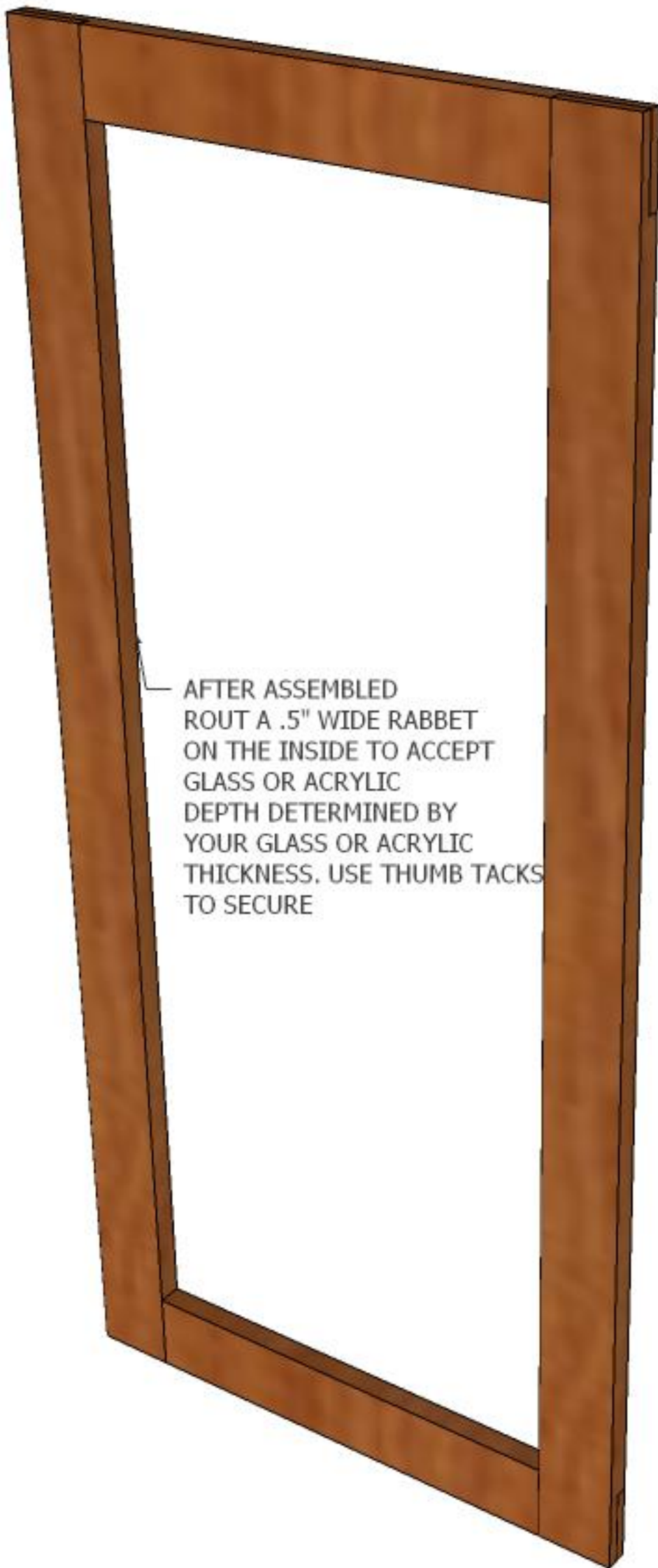

FINAL ASSEMBLY

ADD EITHER TWO HINGES OR
ONE LONG PIANO HINGE

DOOR IS INSET IN FRAME

LOCATE GUITAR HOLDER BASED UPON YOUR GUITAR
MARK OUTLINE WITH TAPE

REMOVE HOLDER AND USE A HAMMER AND NAIL TO LOCATE HOLES
PREDRILL THROUGH BACK INTO HOLDER AND SECURE WITH SCREWS

ADD PULL KNOB OF CHOICE AND
MAGNETIC CATCH SYSTEM OF CHOICE

